



**FIRE**  
GARDEN

LINEAR FIREPIT BURNERS  
& COMPLETE FIREPITS

IT'S ALL ABOUT THE FIRE



**FIRE**  
GARDEN

IT'S ALL ABOUT THE FIRE



*This modern patio features the 36" Firepit Burner. It has been finished with a custom cement base. See installation requirements on page 10.*



Learn more about  
the exciting features and  
benefits of these  
Fire Garden™ products!



## IT'S ALL ABOUT THE FIRE

Fire Garden's new Linear Firepit Burners and Complete Firepits feature the most incredible, alluring presentations of fire you've ever seen! Designed to create the ultimate warmth and outdoor gathering space for any occasion, Fire Garden's mesmerizing flames will bring the magic to 'The Great Outdoors.'

## FIREPIT BURNERS & COMPLETE FIREPITS

Firepit Burners are customizable and ready-to-finish with the materials of your choice.

Three Firepit Burner Sizes: 36", 60", and 120" (Coming Soon)

Complete Firepits are fully-assembled and feature a sleek Black Powder Coated Finish.

Three Complete Firepit Sizes: 48", 72", and 132" (Coming Soon)

## ALL-WEATHER CONSTRUCTION & PERFORMANCE

Featuring heavy-duty stainless steel construction and tempered glass wind guards, Fire Garden™ Firepit Burners and Complete Firepits are perfect for all-weather installation.

These weather-proof units do not require protective covers. They are engineered to be enjoyed in all weather conditions, year-round.

All-Weather 24V Hot Shot™ Electronic Ignition is the most robust and reliable ignition system offered in the industry. This is the same proven system that has been featured on our Tempest Torches for over ten years. You are able to control up to six Fire Garden™ units, including Tempest Torches or Lanterns, with a single switch.

*(Refer to Owner's Manual for more details).*

**Cover photo features the 72" Complete Firepit with Black Powder Coated Finish**



**FIRE**  
GARDEN

IT'S ALL ABOUT THE FIRE



*This rooftop lounge features the 60" Firepit Burner.  
It has been finished with a custom metal surround.*

# ALL-WEATHER CONSTRUCTION BUILT TO LAST



## BURNER MEDIA



Platinum Crushed Glass



Bronze Crushed Glass



Black Crushed Glass



Cobalt Crushed Glass



Tumbled Stones



Rock Embers



*The spectacular 132" Complete Firepit transforms this outdoor space into the ultimate entertainment area! (Coming Soon)*

# SPECIFICATIONS & CLEARANCES

For outdoor installation only. For fixed gas line installations only.

## SPECIFICATIONS

- **Electrical Specification:**

24 VAC., 60 Hz, 1.6 Amps

- **Weight:**

36" Firepit Burner 54 lbs

60" Firepit Burner 83 lbs

120" Firepit Burner 166 lbs

- **Gas Specifications:**

Manifold Pressure

7" wc (NG)

11" wc (LP)

Max. Inlet Pressure      Min. Inlet Pressure

7" wc (NG)                      6" wc (NG)

11" wc (LP)                     10" wc (LP)

- **BTU Input per Hour:**

36" Firepit Burner, 48" Complete Firepit: 65,000\* (NG/LP)

60" Firepit Burner, 72" Complete Firepit: 120,000\* (NG/LP)

120" Firepit Burner, 132" Complete Firepit: 240,000\* (NG/LP)

\*ANSI Standard #Z21.97 requires electronic ignition for any outdoor gas burner with 65,000 BTUs or greater.

## CLEARANCES TO COMBUSTIBLES

36" FIREPIT BURNER, 48" COMPLETE FIREPIT

Minimum Sides 12" (305mm)

Minimum Ceiling 65" (1651mm)

Floor to Top of Burner 10-7/8" (254mm)

60" FIREPIT BURNER, 72" COMPLETE FIREPIT

Minimum Sides 12" (305mm)

Minimum Ceiling 65" (1651mm)

Floor to Top of Burner 10-7/8" (254mm)

120" FIREPIT BURNER, 132" COMPLETE FIREPIT  
(COMING SOON)

Minimum Sides 24" (610mm)

Minimum Ceiling 75" (1905mm)

Floor to Top of Burner 10-7/8" (254mm)

## COMPLETE FIREPIT DIMENSIONS

### Complete Firepits with leveling legs:

48" Complete Firepit 48" L x 24" W x 16-3/8" T

72" Complete Firepit 72" L x 24" W x 16-3/8" T

132" Complete Firepit 132" L x 24" W x 16-3/8" T

# 36" & 60" FIREPIT BURNER DIMENSIONS

36" FIREPIT BURNER

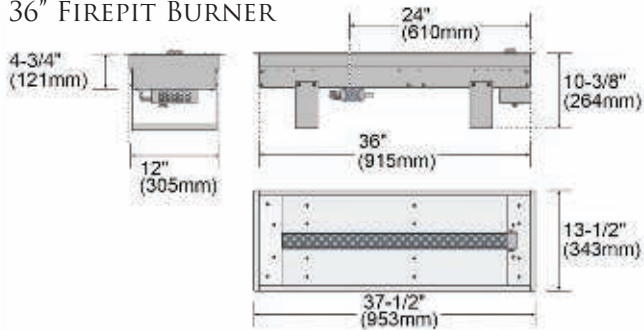

60" FIREPIT BURNER

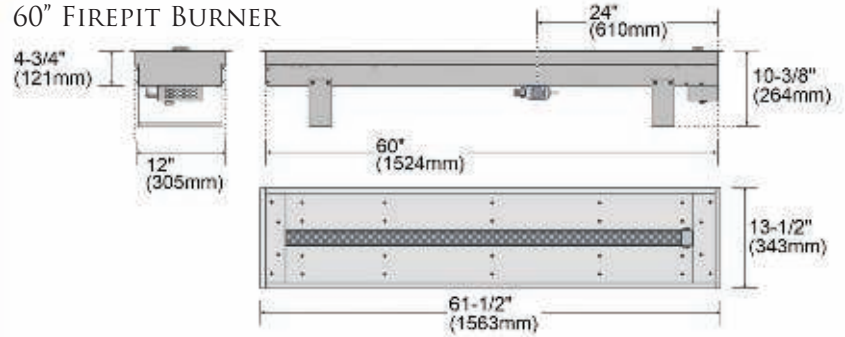

36" GLASS WIND GUARD

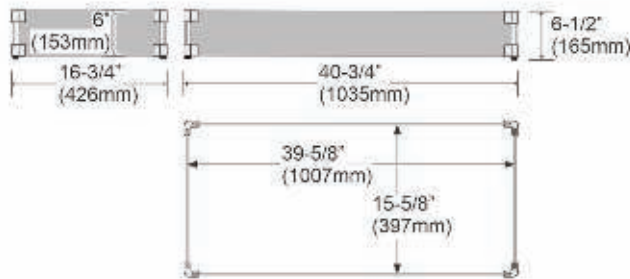

60" GLASS WIND GUARD

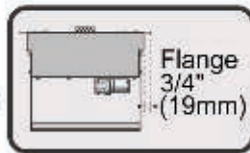
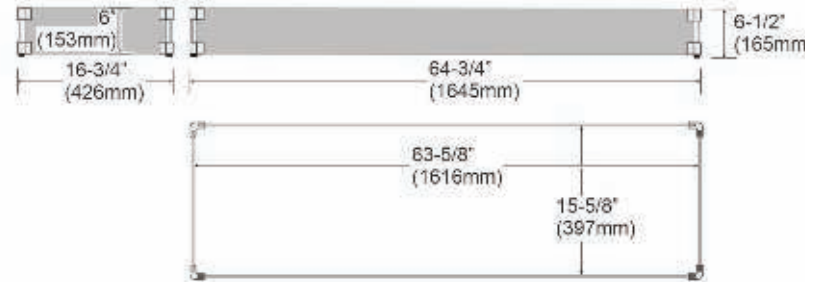



# 120" FIREPIT BURNER DIMENSIONS - COMING SOON

## 120" FIREPIT BURNER

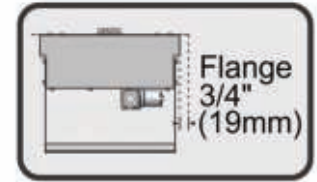
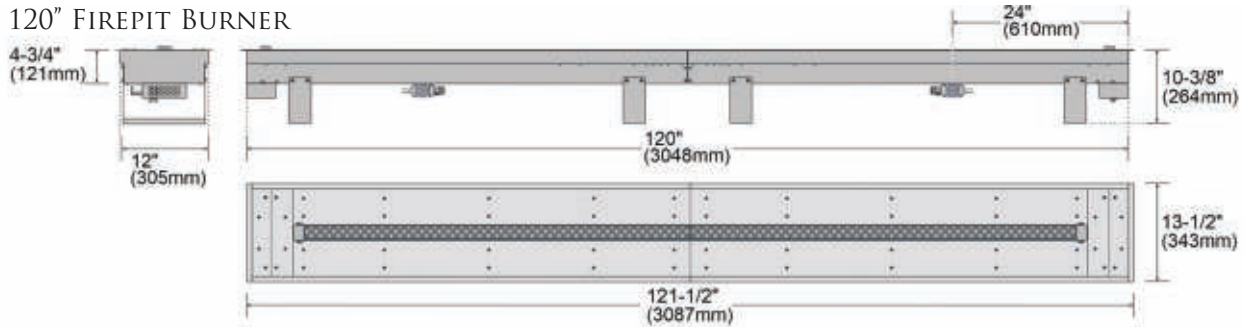

## GLASS WIND GUARD

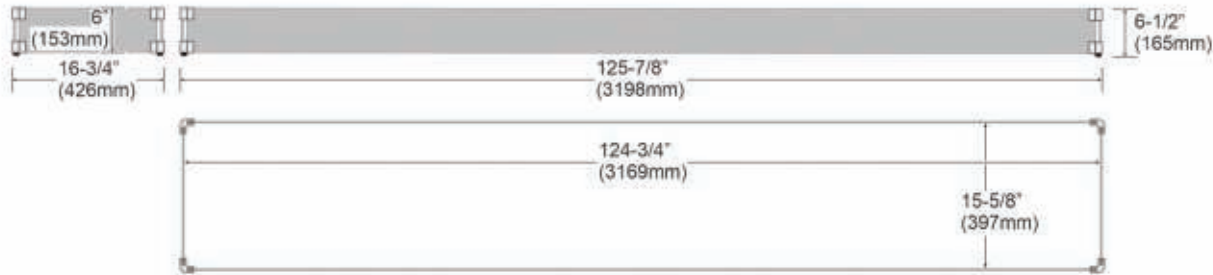

# MINIMUM FRAMING DIMENSIONS

Non-Combustible Framing Required

All Measurements can be +/- 1/8"

36" FIREPIT  
BURNER

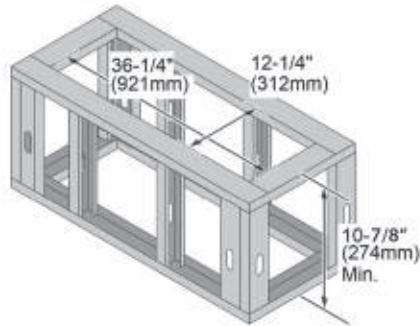

60" FIREPIT  
BURNER

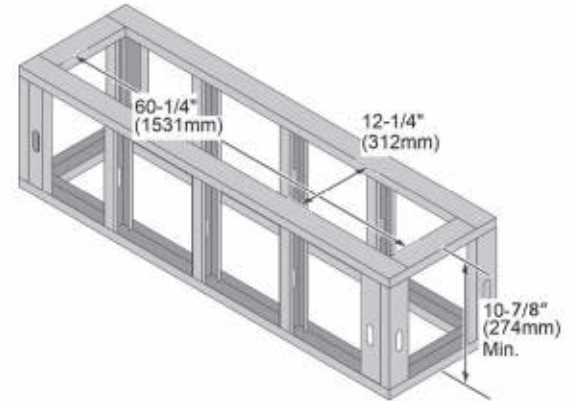

120" FIREPIT  
BURNER

COMING  
SOON

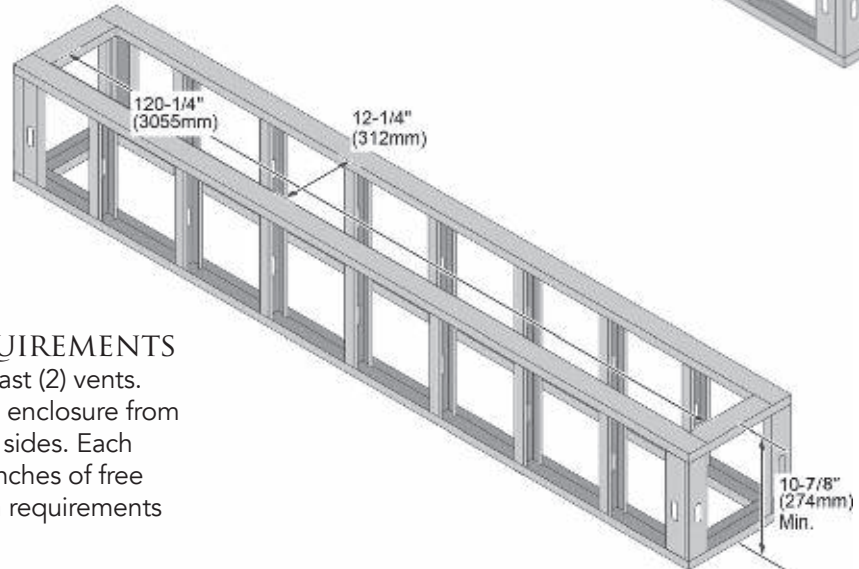

## ENCLOSURE VENTILATION REQUIREMENTS

The linear burner enclosure must have at least (2) vents. The vents must be on opposite sides of the enclosure from each other (either on the ends or along the sides. Each vent must provide a minimum of 9 square inches of free area. See Owner's Manual for all installation requirements

# ENCLOSURE FINISH MATERIAL - MINIMUM DIMENSIONS

The dimensions shown below are the **MINIMUM** to accommodate the glass wind guard. You may choose to make the top surface larger to create more of a usable table surface.

36" FIREPIT  
BURNER

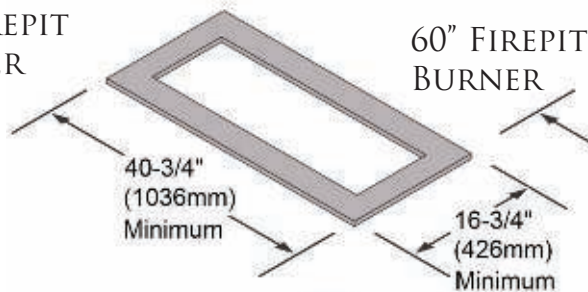

60" FIREPIT  
BURNER

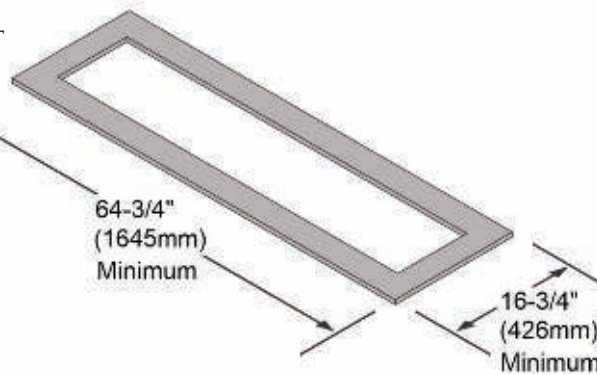

120" FIREPIT  
BURNER

COMING  
SOON

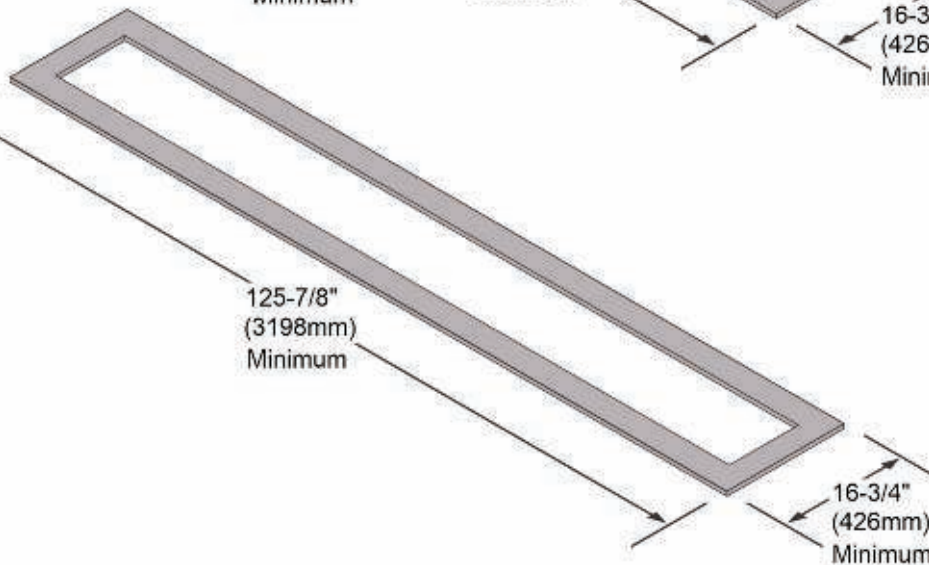



## OTHER FIRE GARDEN™ PRODUCTS

### Tempest Torch™ & Tempest Lantern™

Add the ultimate lighting to any outdoor space!



*Manufactured in  
Mukilteo, WA  
By Travis Industries, Inc*

*Find your favorite  
fire today by visiting:  
[FireGardenOutdoors.com](http://FireGardenOutdoors.com)*

Fire Garden™ manufactures a wide variety of quality outdoor gas appliances. Consult the Owner's Manual for complete installation requirements. We reserve the right to improve our product at any time without prior notification.

Photos and illustrations are for descriptive purposes only. Copyright © 05/2022

#98801065

